

- 1 Proses industri manakah yang menggunakan ferum sebagai mangkin?
Which industrial process uses iron as a catalyst?
- A Pembuatan asid sulfurik
Manufacture of sulphuric acid
 - B Pembuatan marjerin
Manufactured of margarine
 - C Pembuatan ammonia
Manufactured of ammonia
 - D Pembuatan asid nitrik
Manufactured of nitric acid
- 2 Antara berikut, yang manakah **bukan** komponen dalam kaca soda kapur?
*Which of the following is **not** the component of soda lime glass?*
- A Pasir
Sand
 - B Boron oksida
Boron oxide
 - C Kalsium karbonat
Calcium carbonate
 - D Natrium karbonat
Sodium carbonate
- 3 Antara yang berikut yang manakah bukan bahan tambah di dalam detergen?
Which of the following is not additive in detergent?
- A Enzim biologi
Biological enzyme
 - B Pengemulsi
Emulsifier
 - C Agen pemutih
Whitening agent
 - D Pewangi
Fragrance

- 4 Bahan manakah terdiri daripada ion?
Which substance consists of ions?
- A Karbon dioksida
Carbon dioxide
 - B Sulfur dioksida
Sulphur dioxide
 - C Kalsium klorida
Calcium chloride
 - D Hidrogen klorida
Hydrogen chloride
- 5 Antara yang berikut, yang manakah ciri istimewa bagi logam peralihan?
Which of the following is the special characteristic of transition metals?
- A Pepejal lembut
Soft solid
 - B Larut dalam air
Soluble in water
 - C Takat lebur rendah
Low melting point
 - D Membentuk ion berwarna
Form coloured ions

- 6 Rajah 1 menunjukkan model atom satu sebatian.
Diagram 1 shows the atom model of a compound.

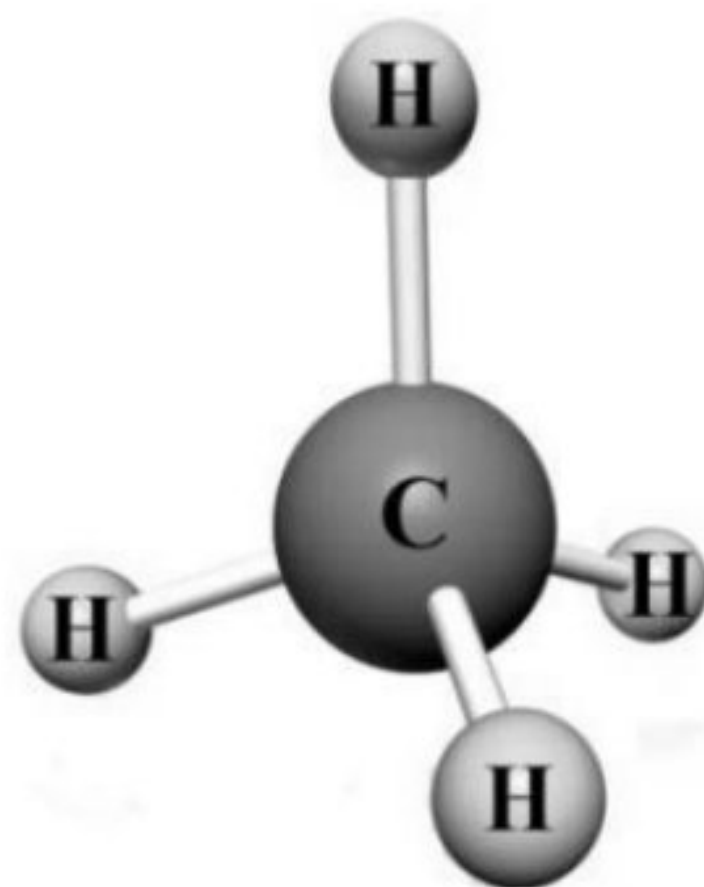

Rajah 1
Diagram 1

Antara berikut, yang manakah sifat sebatian itu?
Which of the following is the property of the compound?

- A Larut dalam air
Dissolves in water
 - B Larut dalam pelarut organik
Dissolve in organic solvent
 - C Takat lebur dan takat didih yang tinggi
High melting and boiling points
 - D Boleh mengkonduksikan elektrik dalam keadaan leburan
Able to conduct electricity in molten state
- 7 Antara yang berikut yang manakah bukan asid kuat?
Which of the following is not strong acid?
- A Asid hidroklorik
Hydrochloric acid
 - B Asid nitrik
Nitric acid
 - C Asid sulfurik
Sulphuric acid
 - D Asid fosforik
Phosphoric acid

- 8 Berikut merupakan sifat-sifat satu bahan buatan dalam industri.
The following are the properties of a manufactured substance.

- Keras tetapi rapuh
Hard but brittle
- Lutsinar
Transparent
- Lengai terhadap bahan kimia
Inert towards chemicals
- Sensitif terhadap keamatan cahaya
Sensitive towards light intensity

Bahan yang manakah mempunyai sifat-sifat seperti di atas?
Which substance has the above properties?

- A Peralatan dapur
Kitchen utensils
- B Kereta lumba
Racing car
- C Kaca mata
Spectacles
- D Prisma
Prism

- 9 Rajah 2 menunjukkan formula struktur suatu sebatian organik.
Diagram 2 shows the structural formula of an organic compound.

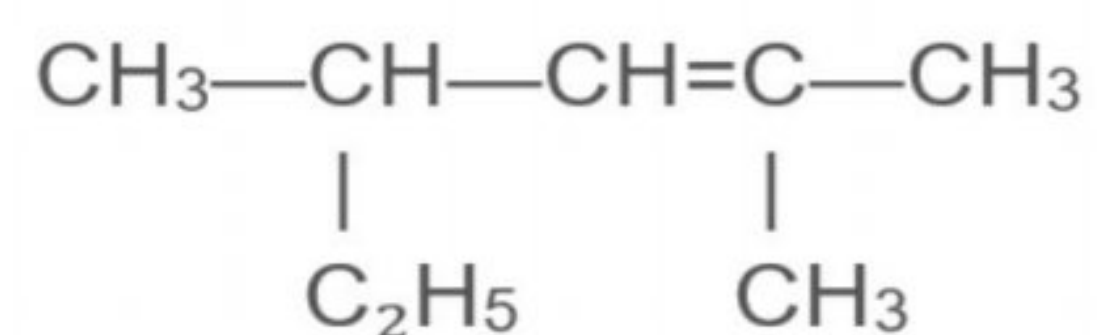

Rajah 2
Diagram 2

Apakah siri homolog bagi sebatian organik?
What is the homologous series for the organic compound?

- A Asid karboksilik
Carboxylic acids
- B Alkana
Alkanes
- C Alkohol
Alcohols
- D Alkena
Alkenes

10 Rajah 3 menunjukkan susunan radas bagi menentukan haba pembakaran etanol, C₂H₅OH. *Diagram 3 shows the experimental set-up to determine the heat of combustion of ethanol, C₂H₅OH.*

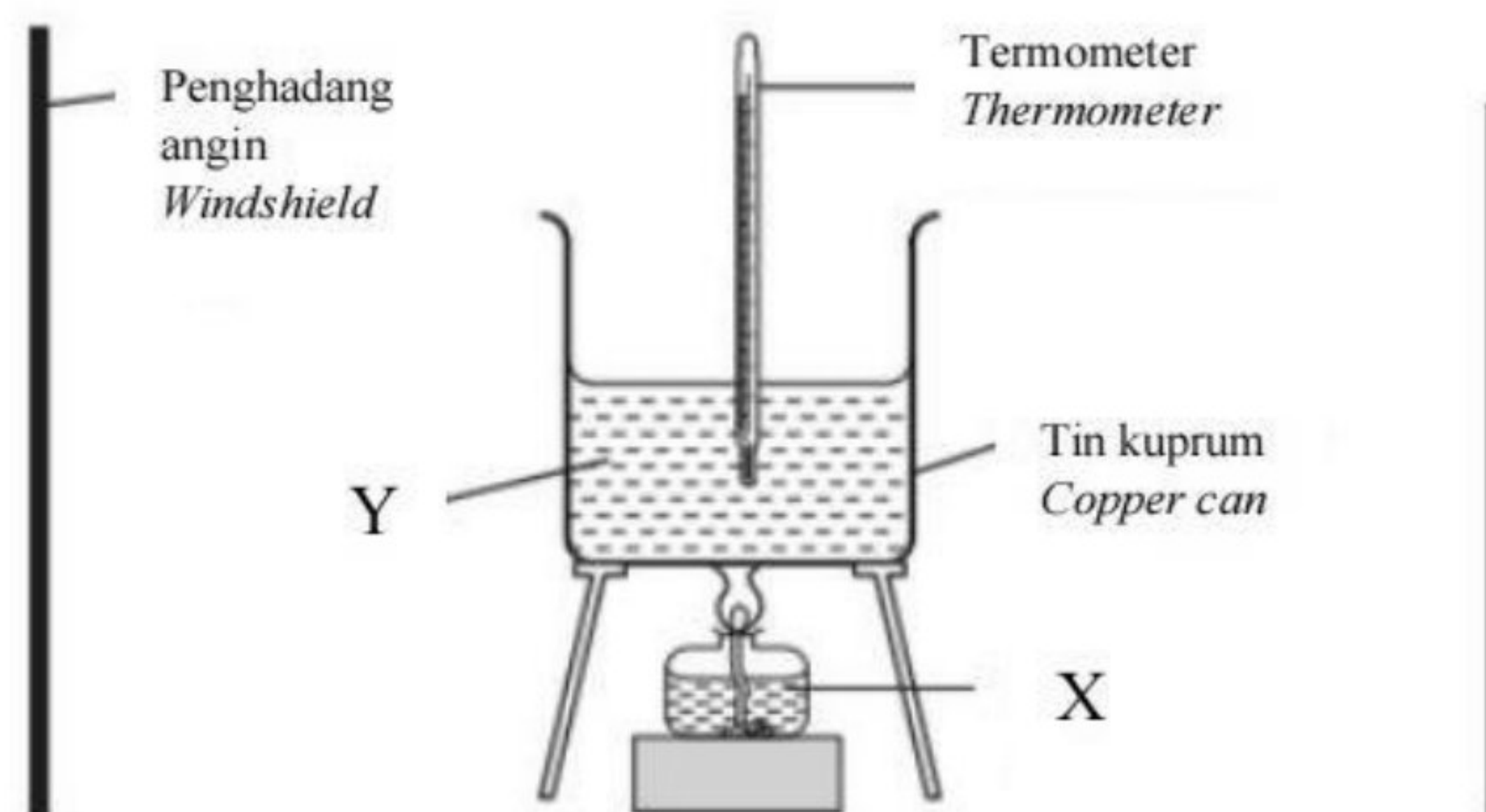

Apakah yang sesuai bagi X dan Y?
What is appropriate for X and Y?

Rajah 3
Diagram 3

	X	Y
A	Etanol <i>Ethanol</i>	Air <i>Water</i>
B	Air <i>Water</i>	Etanol <i>Ethanol</i>
C	Naftalena <i>Naphthalene</i>	Air <i>Water</i>
D	Air <i>Water</i>	Naftalena <i>Naphthalene</i>

- 11 Yang manakah bukan polimer semula jadi?
Which of the following is not a natural polymer?
- A Selulosa
Cellulose
 - B Polistirena
Polystyrene
 - C Poliisoprena
Polyisoprene
- 12 Apakah bahan kimia yang ditambah untuk menghalang makanan daripada menjadi tengik?
What are the chemical substances added to prevent food from becoming rancid?
- A Pengantioksida
Antioxidant
 - B Penstabil
Stabiliser
 - C Pewarna
Dye
 - D Pemekat
Thickener
- 13 Siapakah yang menjumpai neutron?
Who discovered neutrons?
- A Neils Bohr
 - B J. J. Thomson
 - C James Chadwick
 - D Ernest Rutherford
- 14 Antara berikut manakah merupakan nombor bagi pemalar Avogadro, N_A ?
Which of the following is the number for Avogadro's constant, N_A ?
- A $6.02 \times 10^{-24} \text{ mol}^{-1}$
 - B $6.02 \times 10^{23} \text{ mol}^{-1}$
 - C $6.02 \times 10^{24} \text{ mol}^{-1}$
 - D $6.02 \times 10^{-23} \text{ mol}^{-1}$

15 Apakah prinsip asas yang digunakan dalam penyusunan unsur dalam Jadual Berkala Unsur?

What is the basic principle used in the arrangement of elements in the Periodic Table of Elements?

- A Peningkatan nombor nukleon
Ascending nucleon number
- B Peningkatan jisim atom relatif
Ascending relative atomic mass
- C Peningkatan nombor proton
Ascending proton number
- D Peningkatan bilangan elektron
Ascending number of electron

16 Sebatian manakah merupakan sebatian kovalen?

Which compound is covalent compound?

- I Magnesium oksida, MgO
Magnesium oxide, MgO
 - II Litium klorida, LiCl
Lithium chloride, LiCl
 - III Butana, C₄H₁₀
Butane, C₄H₁₀
 - IV Tetraklorometana, CCl₄
Tetrachloromethane, CCl₄
- A I dan II
I and II
 - B I dan IV
I and IV
 - C II dan III
II and III
 - D III dan IV
III and IV

17 Asid yang mempunyai nilai kebesan 2 ialah
Acid which has a basicity value of 2 is

- A asid karbonik.
carbonic acid.
- B asid etanoik.
ethanoic acid.
- C asid hidroklorik.
hydrochloric acid.
- D asid nitrik.
nitric acid.

18 Kepingan marmar bertindak balas dengan asid hidroklorik untuk menghasilkan karbon dioksida. Persamaan untuk tindak balas adalah seperti berikut :
Marble chips react with hydrochloric acid to produce carbon dioxide. The equation for the reaction is as follows :



Antara berikut, yang manakah akan merendahkan kadar tindak balas ini?
Which of the following will lower the rate of the reaction?

- A Menggunakan kepekatan asid hidroklorik yang lebih cair
Using a more dilute concentration of hydrochloric acid
- B Menggunakan kepingan marmar bersaiz lebih kecil
Use smaller sized marble chips
- C Menggunakan isipadu asid hidroklorik yang lebih besar
Use a larger volume of hydrochloric acid
- D Menggunakan kepingan marmar yang mempunyai luas permukaan yang lebih besar
Use marble chips that have a larger surface area

19

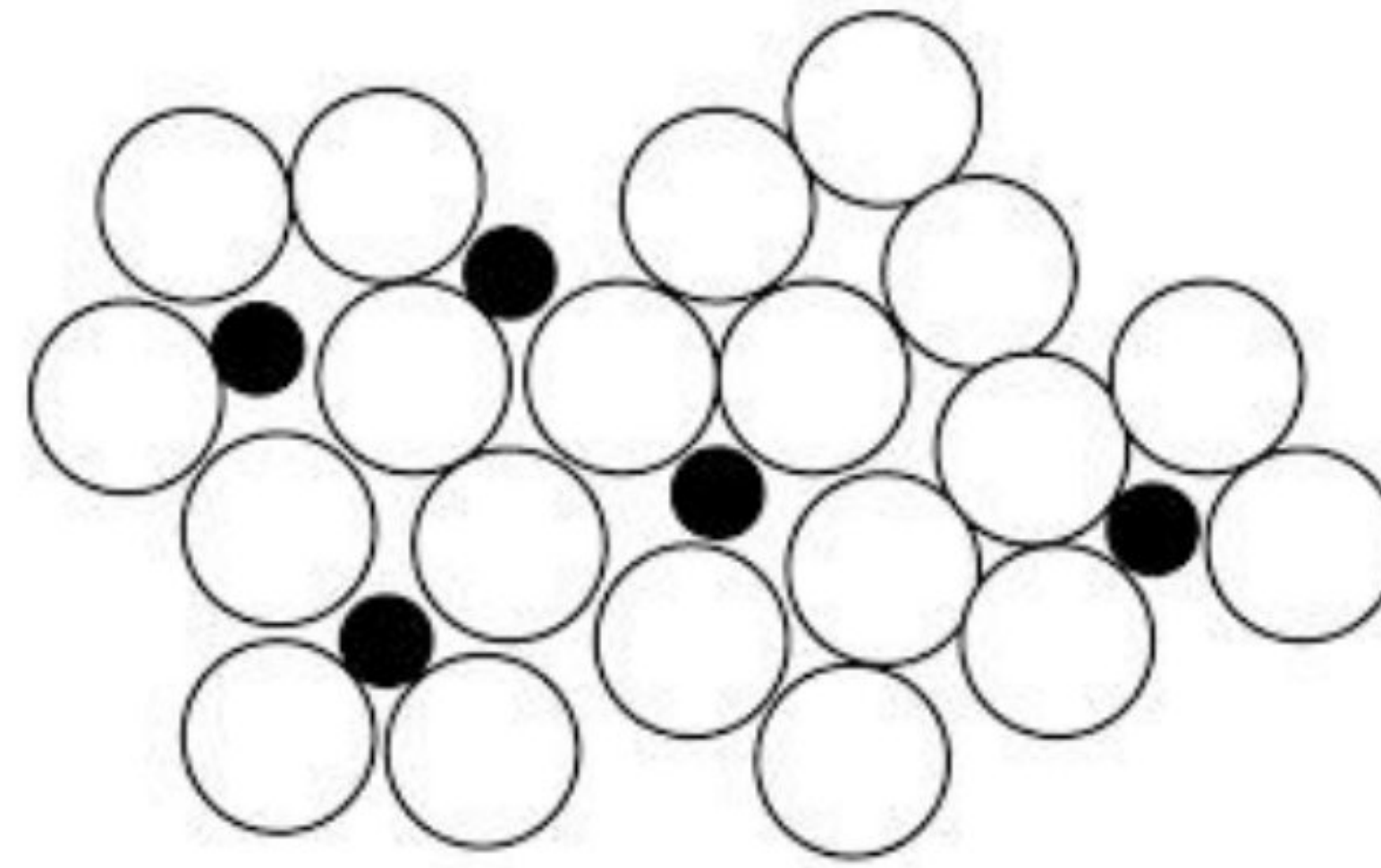

Rajah 4
Diagram 4

Rajah 4 menunjukkan suatu komposisi aloi. Manakah antara berikut mewakili struktur tersebut?

Diagram 4 shows the composition of an alloy. Which of the following represents the alloy?

- A Keluli nirkarat
Stainless steel
- B Duralumin
Duralumin
- C Piuter
Pewter
- D Keluli
Steel

- 20 Jadual 1 menunjukkan takat lebur dan takat didih bahan W, X, Y dan Z.
Table 1 below shows the melting and boiling points of substances W, X, Y and Z.

Bahan <i>Substance</i>	Takat lebur (°C) <i>Melting point (°C)</i>	Takat didih (°C) <i>Boiling point (°C)</i>
W	-75	-15
X	-20	97
Y	35	147
Z	5	120

Jadual 1
Table 1

Bahan yang manakah cecair pada suhu bilik?
Which substance is a liquid at room temperature?

- A X dan Z
X and Z
- B Y dan Z
Y and Z
- C W sahaja
W only
- D X sahaja
X only
- 21 Antara persamaan kimia berikut, yang manakah bukan tindak balas redoks?
Which of the following chemical equations is not a redox reaction?
- A $\text{Ag}^+ + \text{Cl}^- \rightarrow \text{AgCl}$
- B $\text{Cl}_2 + \text{S}^{2-} \rightarrow 2\text{Cl}^- + \text{S}$
- C $2\text{Fe}^{3+} + \text{Zn} \rightarrow 2\text{Fe}^{2+} + \text{Zn}^{2+}$
- D $\text{Mg} + \text{Cu}^{2+} \rightarrow \text{Mg}^{2+} + \text{Cu}$

- 22 Formula molekul berikut mewakili satu sebatian karbon yang terbentuk daripada tindak balas antara sebatian X dan sebatian Y.

The following molecular formula represents a carbon compound formed from the reaction between compounds X and Y.



Apakah sebatian X dan sebatian Y?

What are compounds X and Y?

	Sebatian X <i>Compound X</i>	Sebatian Y <i>Compound Y</i>
A	$\text{CH}_3\text{CH}_2\text{COOH}$	$\text{CH}_3\text{CH}_2\text{OH}$
B	$\text{CH}_2\text{CH}_2\text{CH}_2\text{CH}_2\text{COOH}$	$\text{CH}_3\text{CH}_2\text{CH}_2\text{OH}$
C	$\text{CH}_3\text{CH}_2\text{CH}_2\text{COOH}$	$\text{CH}_3\text{CH}_2\text{OH}$
D	$\text{CH}_3\text{CH}_2\text{COOH}$	$\text{CH}_3\text{CH}_2\text{CH}_2\text{OH}$

23

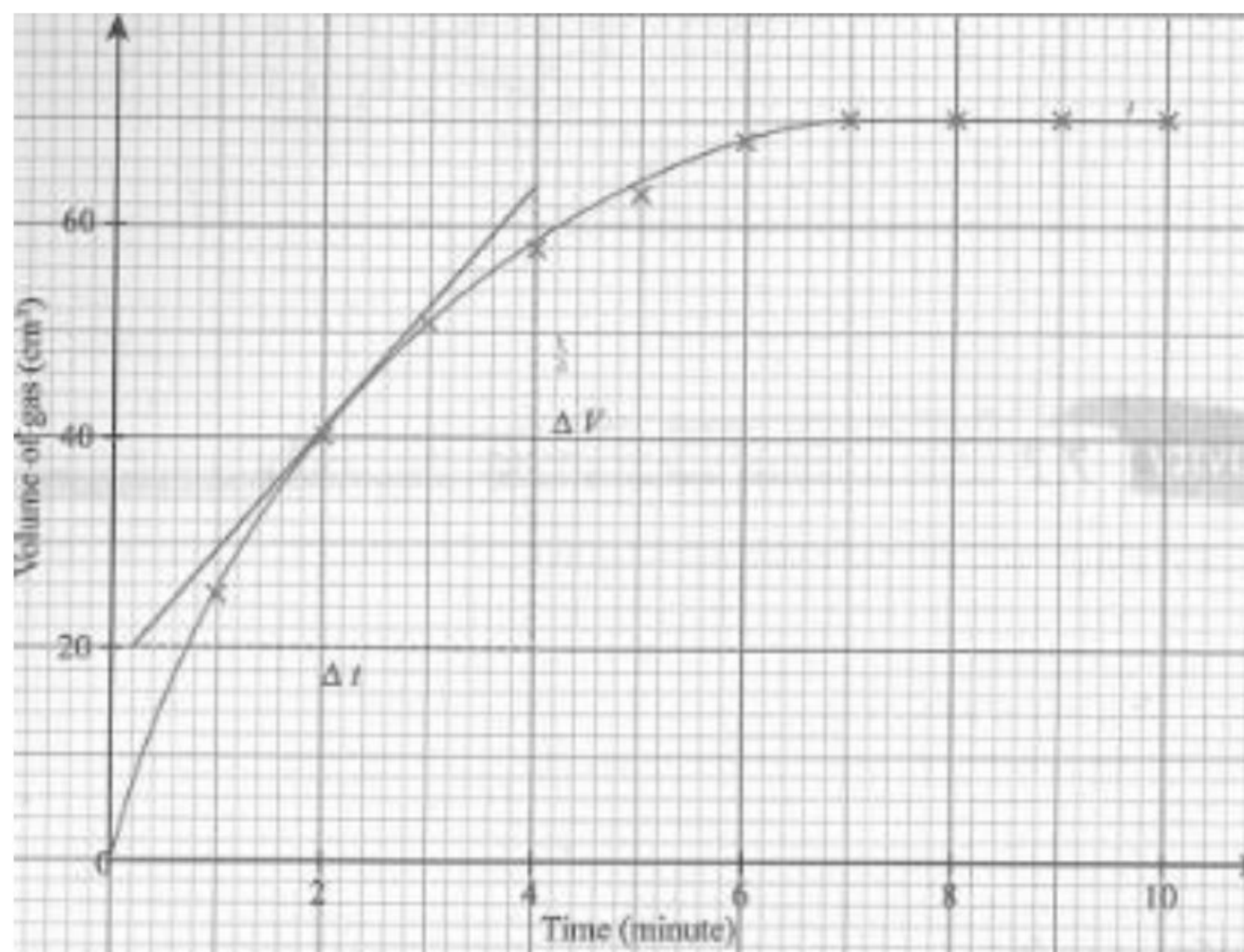

Graf 1
Graph 1

Berdasarkan graf 1, kira kadar tindak balas purata bagi tindak balas ini.
Based on the graph 1, calculate the average rate of reaction for this reaction.

- A 7.00 cm³ min⁻¹
- B 10.00 cm³ min⁻¹
- C 6.50 cm³ min⁻¹
- D 6.00 cm³ min⁻¹

- 24 Rajah 5 menunjukkan tindak balas antara serbuk zink dan larutan kuprum(II) sulfat.
Diagram 5 shows reaction between zinc powder and copper(II) sulphate solution.

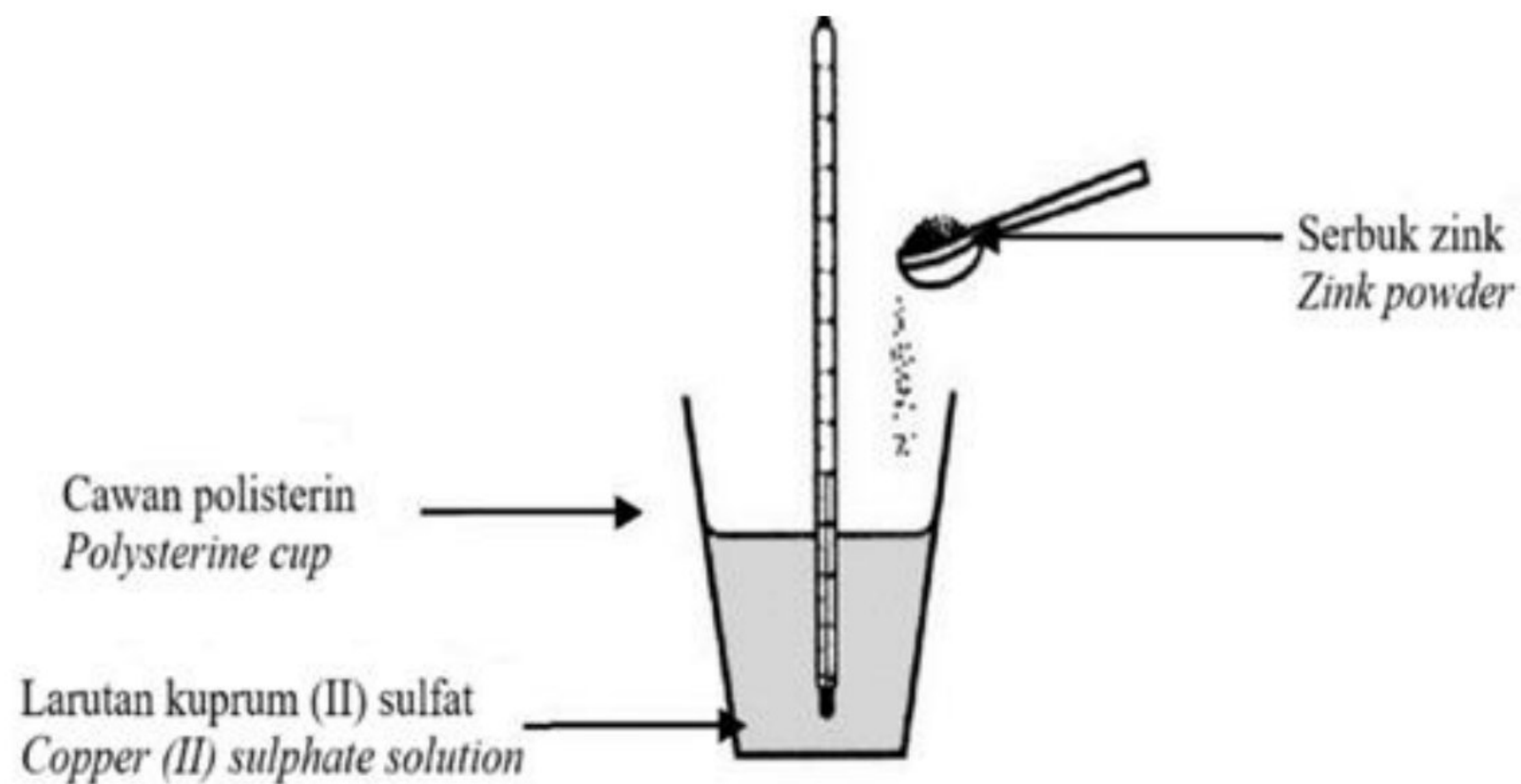

Rajah 5
Diagram 5

Antara yang berikut yang manakah menerangkan tindak balas di atas?
Which of the following explained about the reaction?

- A Perubahan haba apabila 1 mol halogen disesarkan oleh larutan halidanya.
Heat changes when 1 mol of halogen is displaced from its salt solution.
- B Perubahan haba apabila 1 mol ion dihasilkan daripada logamnya.
Heat changes when 1 mol of ion is produced from its metal.
- C Perubahan haba apabila 1 mol logam disesarkan daripada larutan garamnya.
Heat changes when 1 mol of metal is displaced from its salt solution.

25 Rajah 6 menunjukkan molekul asid fosforik.

Diagram 6 shows a phosphoric acid molecule.

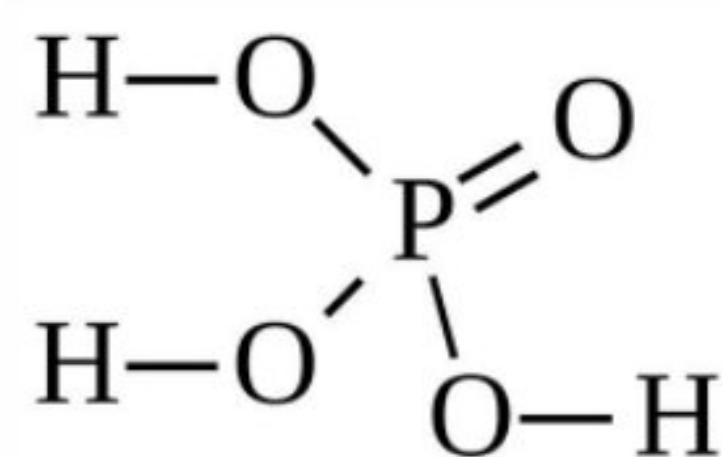

Rajah 6

Diagram 6

Berapakah bilangan elektron yang terlibat dalam pembentukan semua ikatan kovalen dalam satu molekul asid fosforik?

How many electrons are involved in the formation of all covalent bonds in the phosphoric acid molecule?

- A 7
- B 8
- C 12
- D 16

26 Rajah 7 menunjukkan formula struktur monomer getah.

Diagram 7 shows the structural formula of rubber monomer.

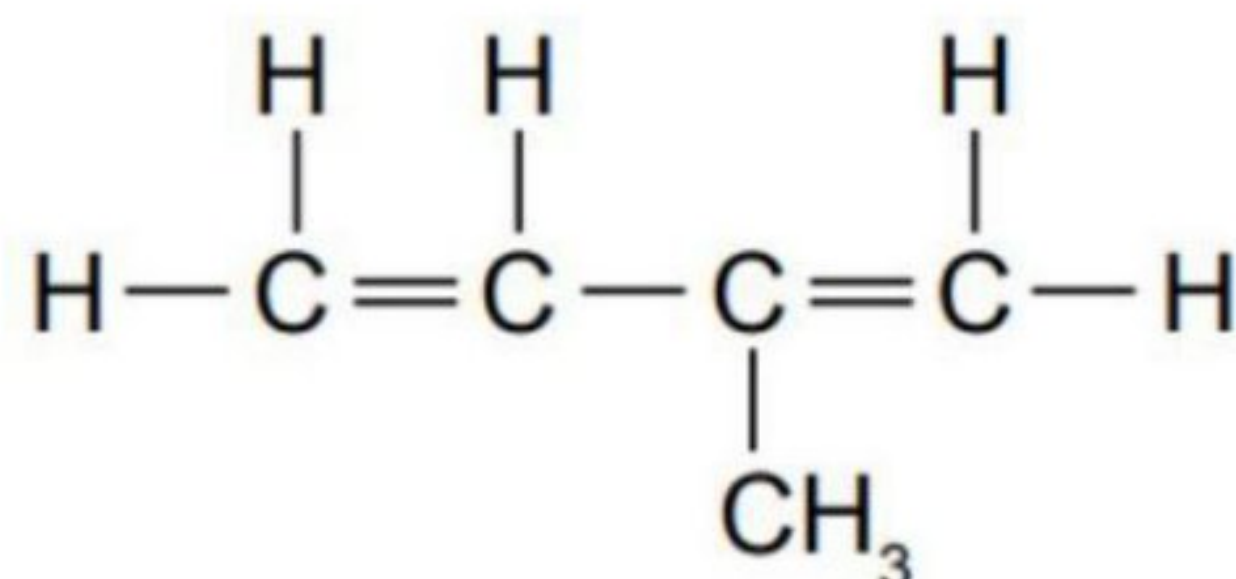

Rajah 7

Diagram 7

Apakah nama sebatian tersebut berdasarkan sistem penamaan IUPAC?

What is the name of the compound based on the IUPAC nomenclature?

- A 3-metilbutena
3-methylbutene
- B 2-metilpentena
2-methylpentene
- C 2-metilbut-1,3-diena
2-methylbut-1,3-diene
- D 3-metilbut-1,3-diena
3-methylbut-1,3-diene

27 Yang manakah antara berikut merupakan hasil pempolimeran kondensasi?
Which of the following products of condensation polymerisation?

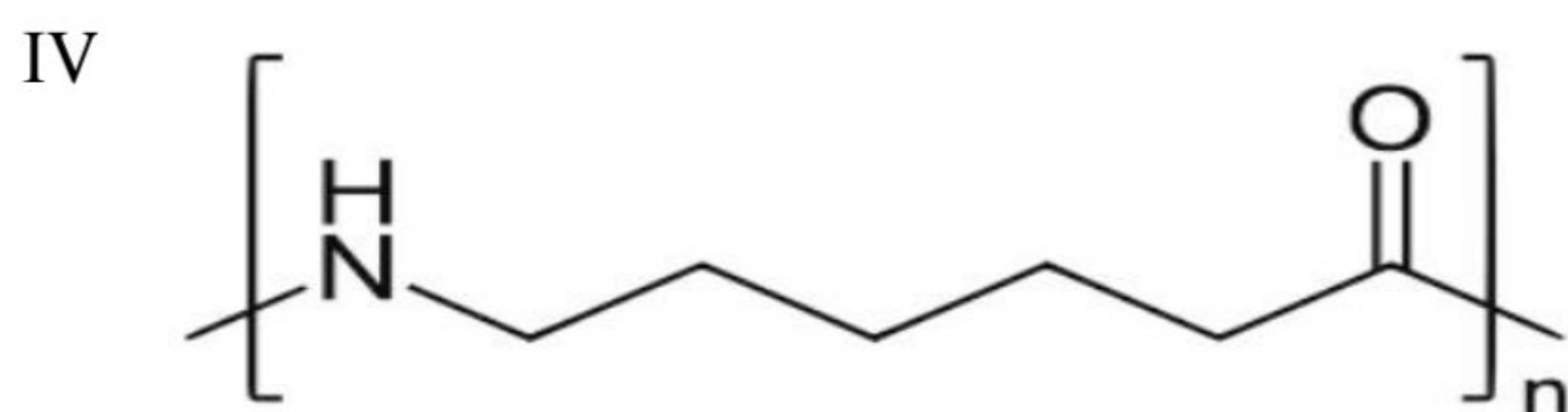
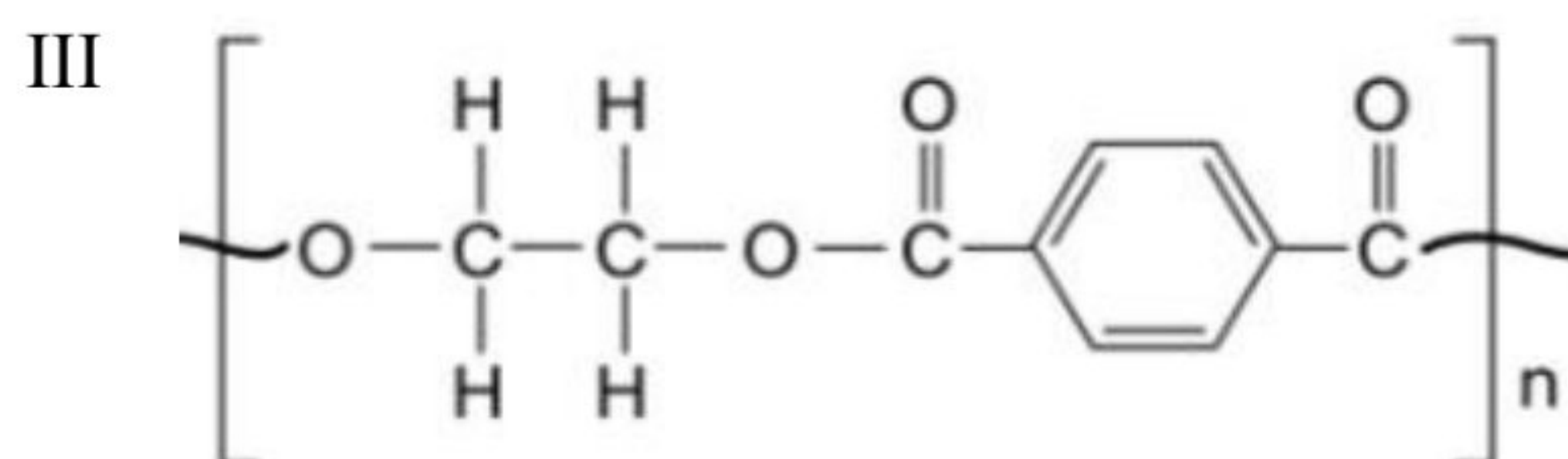
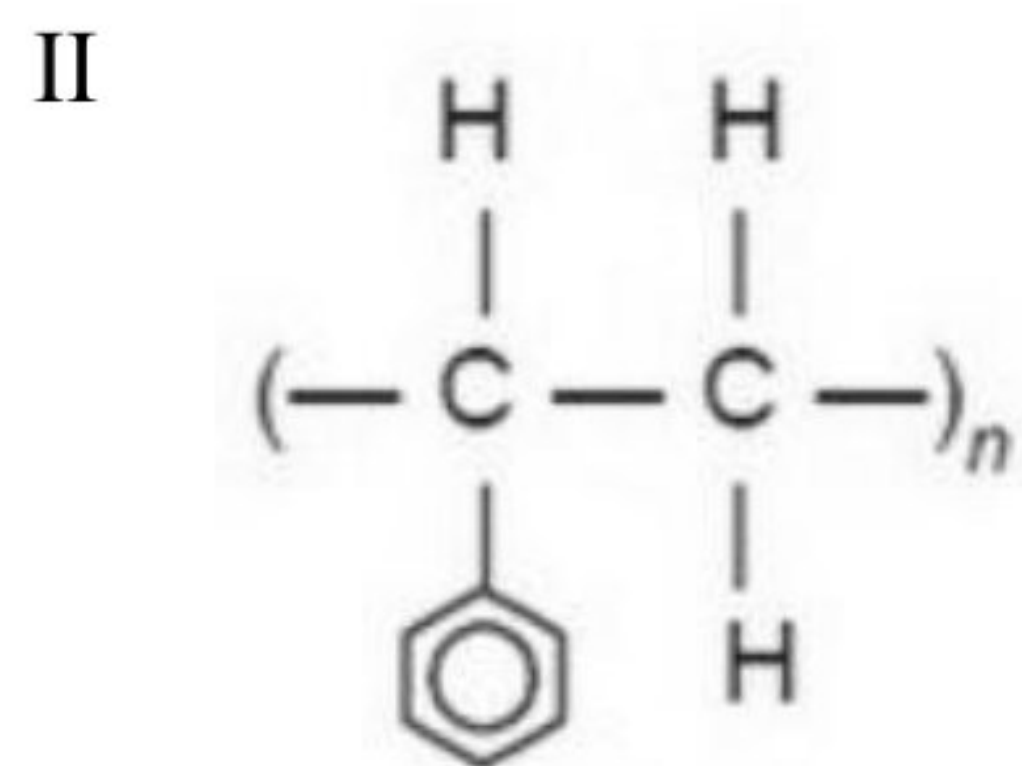
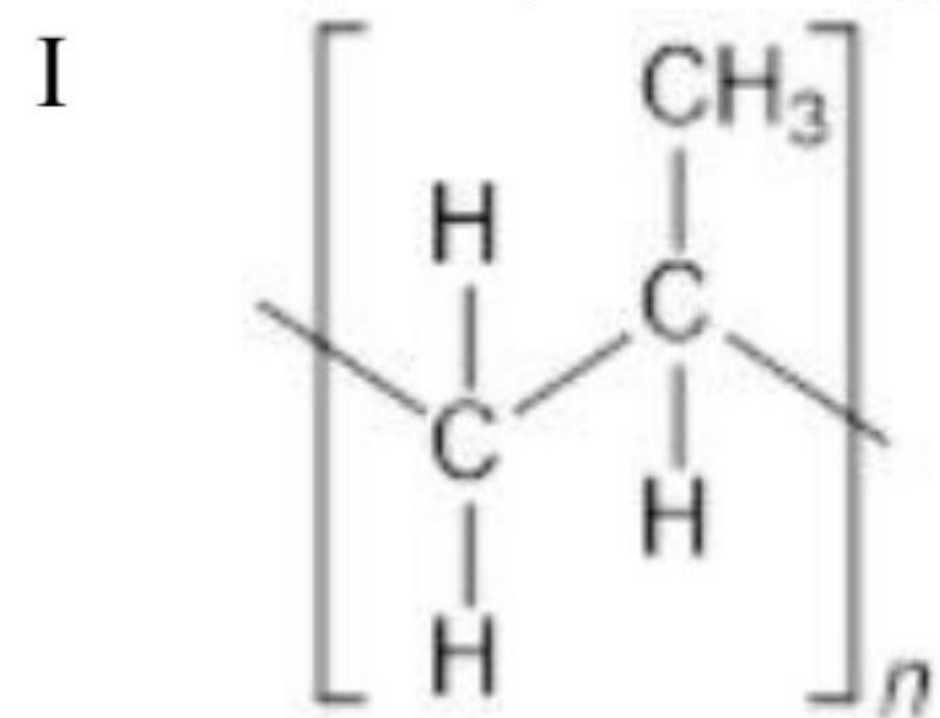

- A I dan II
I and II
- B II dan III
II and III
- C III dan IV
III and IV
- D I dan IV
I and IV

- 28 Rajah 8 menunjukkan proses rawatan X.
Diagram 8 shows X treatment process.

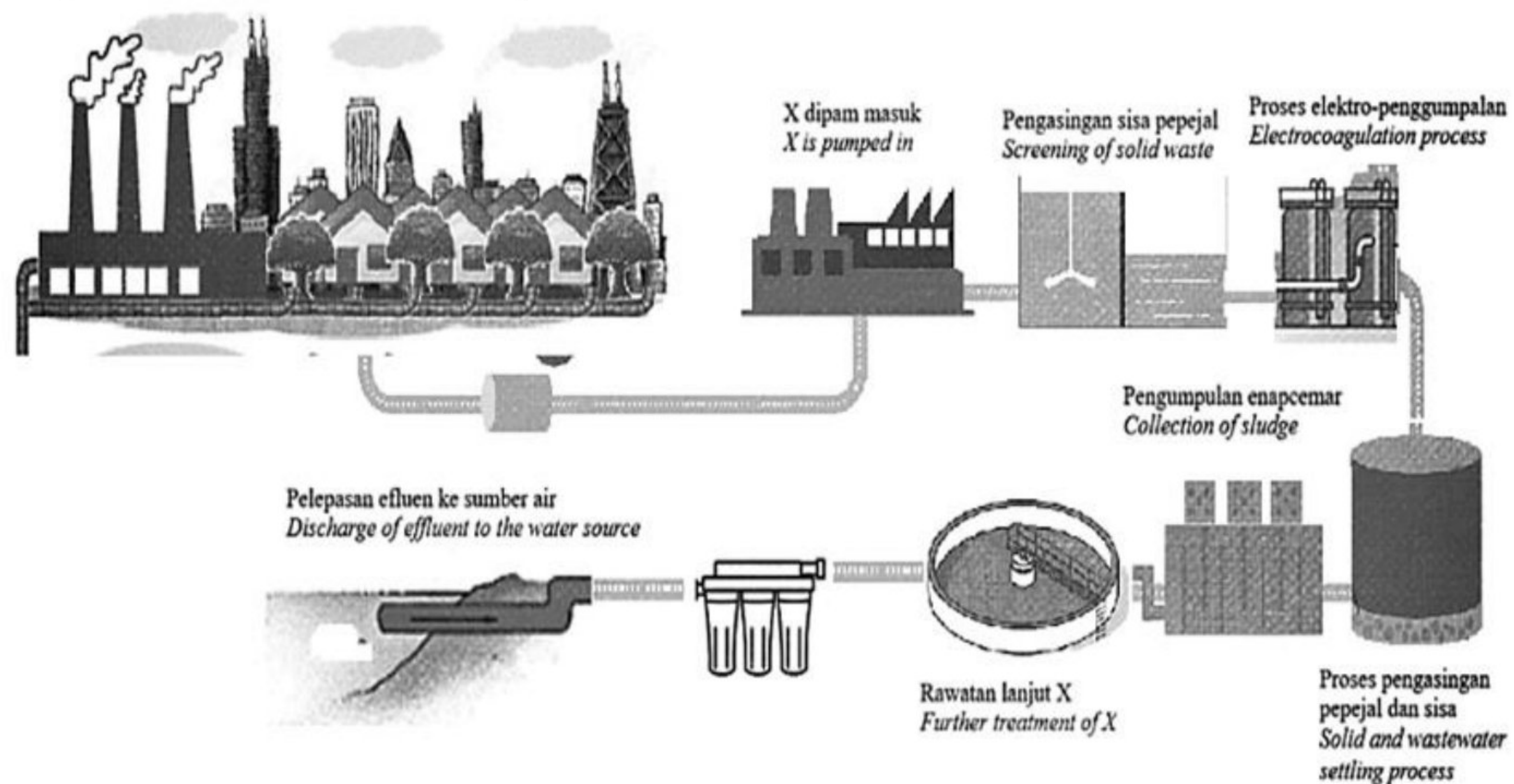

Rajah 8
Diagram 8

Pilih pernyataan yang betul untuk menerangkan hasil X?
Choose the correct statement to explain the product of X?

- A Air sisa mengandungi akrilonitril, toluena dan metilbenzena
Wastewater consists of acrylonitrile, toluene and methylbenzene
- B Bahan enap cemar setelah dirawat dengan betul boleh digunakan sebagai baja dalam sektor pertanian
After proper treatment, sludge can be used as fertilizers for the agriculture sector
- C Air sisa dapat digunakan untuk pengairan tanaman
Wastewater that has been treated can be reused for crop irrigation
- D Air sisa disingkirkan sebagai efluen
Wastewater can be discharged as effluent.

29 Antara yang berikut, yang manakah betul mengenai perubahan sifat unsur apabila merentasi kala dalam Jadual Berkala Unsur?

Which of the following is the correct change in the property of elements across the period in the Periodic Table of Elements?

- A Jejari atom meningkat
The atomic radius increases
- B Bilangan proton dalam setiap atom meningkat
The number of protons in each atom increases
- C Bilangan elektron valens dalam setiap atom berkurang
The number of valence electrons in each atom decreases

30 Antara berikut, yang manakah ciri gas hidrogen klorida yang membolehkan sifat keasidan dapat ditunjukkan?

Which of the following is the characteristic of hydrogen chloride gas that enables its acidic properties to be shown?

- A Mengion di dalam air
Ionise in water
- B Melarut di dalam air
Dissolve in water
- C Mengandungi ion hidrogen dalam molekul
Contains hydrogen ion in its molecule
- D Mengion dalam air dan menghasilkan ion hidrogen
Ionise in water and produce hydrogen ion

31

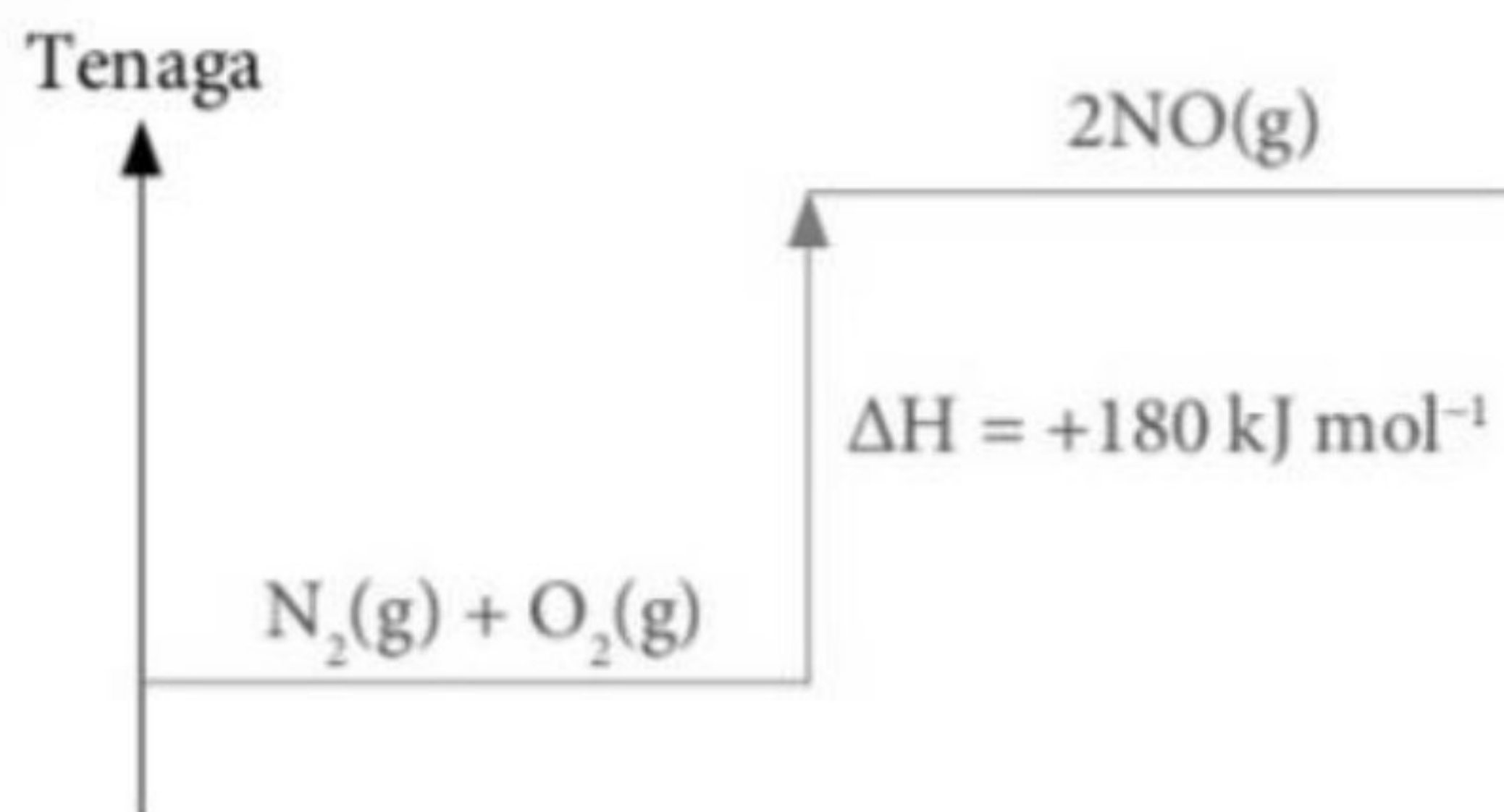

Rajah 9
Diagram 9

Rajah 9 menunjukkan gambarajah aras tenaga. Manakah antara berikut tidak menerangkan tindak balas dalam Rajah 9?

Diagram 9 shows an energy level diagram. Which of the following does not explain the reaction in Diagram 9?

- A Tindak balas eksotermik
Exothermic reaction
- B Tindak balas endotermik
Endothermic reaction
- C Suhu menurun
Temperature decrease
- D Haba diserap
Heat absorbed

- 32 Penguraian kalium klorat(V), KClO_3 oleh haba selalu digunakan untuk menghasilkan gas oksigen di dalam makmal.

Decomposition of potassium chlorate(V), KClO_3 by heat is often used to produce oxygen gas in the laboratory.



Jika anda seorang pembantu makmal, berapakah jisim kalium klorat(V), KClO_3 yang diperlukan untuk menghasilkan 20 dm^3 gas oksigen?

If you are a lab assistant, what are the masses of potassium chlorate(V), KClO_3 needed to produce 20 dm^3 of oxygen gas?

[Jisim atom relatif : O = 16, Cl = 35.5, K = 39; Isipadu molar : $24 \text{ dm}^3 \text{ mol}^{-1}$ pada keadaan bilik]

[Relative atomic mass : O = 16, Cl = 35.5, K = 39; Molar volume : $24 \text{ dm}^3 \text{ mol}^{-1}$ at room conditions]

- A 68.1 g
- B 102.1 g
- C 50.68 g
- D 153.06 g

- 33 Rajah 10 menunjukkan formula struktur bagi suatu sebatian.

Diagram 10 shows the structural formula of a compound.

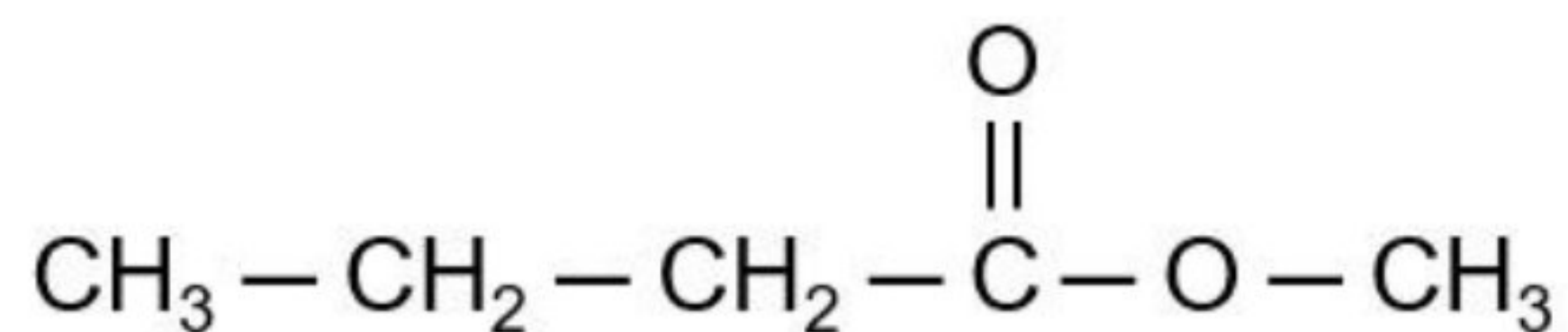

Rajah 10

Diagram 10

Apakah nama bagi sebatian tersebut?

What is the name of the compound?

- A Butil pentanoat
Butyl pentanoate
- B Butil propanoat
Butyl propanoate
- C Pentil pentanoat
Pentyl pentanoate
- D Metil butanoat
Methyl butanoate
- 34 4.16 g unsur W bertindak balas dengan 1.92 g oksigen untuk membentuk oksida logam W. Formula empirik bagi oksida logam ini ialah W_2O_3 . Berapakah jisim atom relatif W?
[Jisim atom relatif : O = 16]
4.16 g of element W reacts with 1.92 g of oxygen to form metal oxide W. The empirical formula for this metal oxide is W_2O_3 . What is the relative atomic mass of W?
[Relative atomic mass : O = 16]
- A 27
- B 52
- C 56
- D 104

35

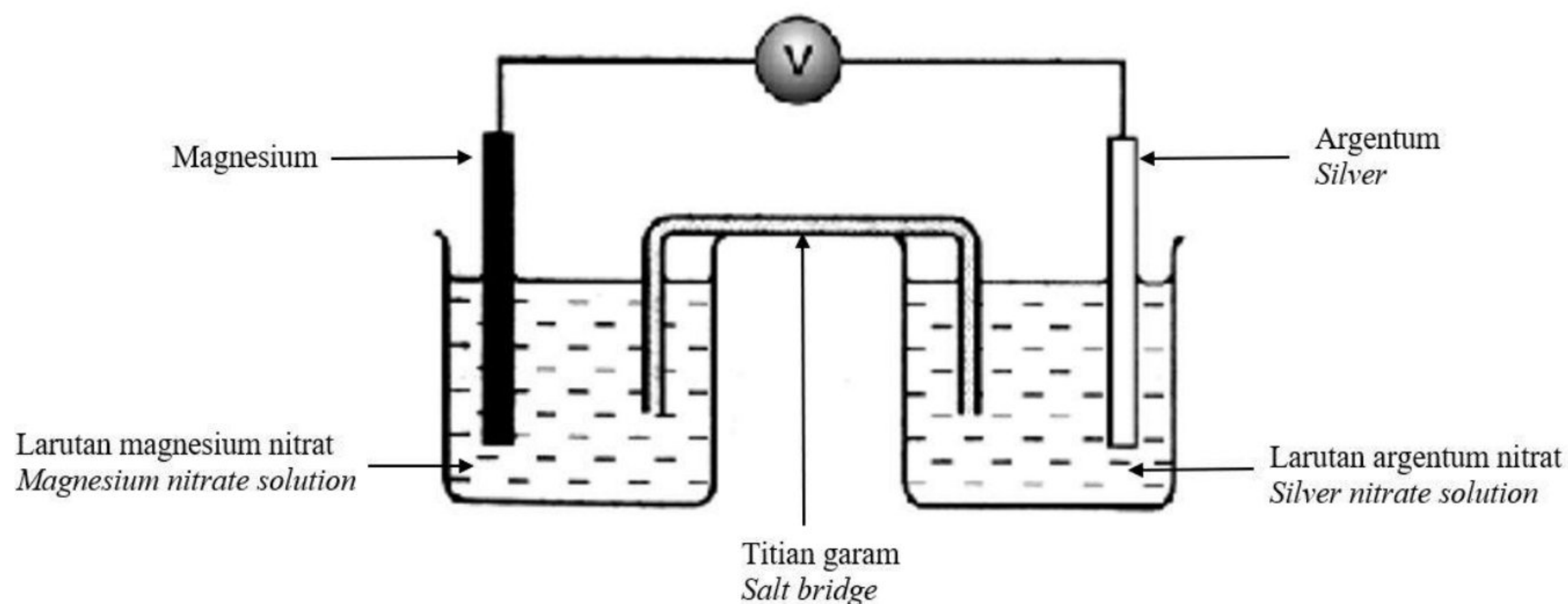

Rajah 11
Diagram 11

$\text{Mg}^{2+} (\text{ak/aq}) + 2\text{e}^- \rightleftharpoons \text{Mg} (\text{p/s})$	$E^\circ = -2.38 \text{ V}$
$\text{Ag}^{2+} (\text{ak/aq}) + \text{e}^- \rightleftharpoons \text{Ag} (\text{p/s})$	$E^\circ = +0.80 \text{ V}$

Rajah 11 menunjukkan satu susunan radas sel kimia satu tindak balas redoks.
Diagram 11 shows the apparatus arrangement of a chemical cell in a redox reaction.

Apakah bacaan voltmeter dalam Rajah 11?
What is the voltmeter reading in Diagram 11?

- A 0.96 V
- B 3.18 V
- C -1.58 V
- D -2.38 V

- 36 0.2 mol ketulan magnesium sulfat bertindakbalas dengan asid sulfurik cair berlebihan. Selepas 1.0 minit, didapati 0.05 mol magnesium karbonat tertinggal sebagai baki. Berapakah kadar purata bagi tindak balas itu?

0.2 mol of magnesium carbonate crystals react with excess sulphuric acid. After 1.0 minute, 0.05 mol of magnesium carbonate remains as residue. What is the average rate of the rate of reaction?

[Jisim atom relatif : Mg = 24, C = 12, O = 16]

[Relative atomic mass: Mg = 24, C = 12, O = 16]

- A 0.07 g s⁻¹
B 0.0025 g s⁻¹
C 0.28 g s⁻¹
D 0.21 g s⁻¹
- 37 Persamaan kimia di bawah mewakili tindak balas kimia bagi penyediaan garam terlarutkan, zink sulfat.

The chemical equation below represents the chemical reaction for the preparation of a soluble salt, zinc sulphate.

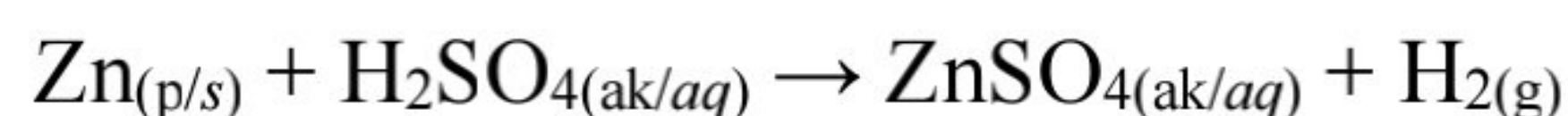

3.5 g serbuk zink ditambah ke dalam 50 cm³ asid sulfurik 0.60 mol dm⁻³. Berapakah jisim bagi serbuk zink yang tidak bertindak balas?

[Jisim atom relatif : Zn = 65]

3.5 g of zinc powder is added to 50 cm³ of 0.60 mol dm⁻³ sulphuric acid. What is the mass of unreacted zinc powder?

[Relative atomic mass : Zn = 65]

- A 0.43 g
B 0.75 g
C 1.55 g
D 1.95 g

- 38 Persamaan termokimia berikut mewakili tindak balas peneutralan di antara 25 cm³ asid nitrik dan 25 cm³ larutan kalium hidroksida yang sama kemolaran. Suhu campuran meningkat sebanyak 7 °C.

[Muatan haba tentu larutan = 4.2 J g⁻¹ °C⁻¹, Ketumpatan larutan = 1 g cm⁻³]

The following thermochemical equation represents the neutralization reaction between 25 cm³ nitric acid and 25 cm³ potassium hydroxide solution of the same molarity. The temperature of the mixture increased by 7 °C.

[Specific heat capacity of the solution = 4.2 J g⁻¹ °C⁻¹, Density of the solution = 1 g cm⁻³]

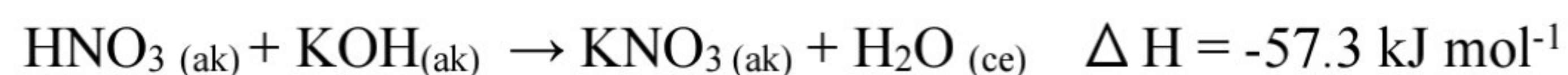

Apakah kemolaran bagi kedua-dua larutan?

What is the molarity of both solutions?

- A 0.52 mol dm⁻³
- B 1.03 mol dm⁻³
- C 2.10 mol dm⁻³
- D 2.24 mol dm⁻³

39

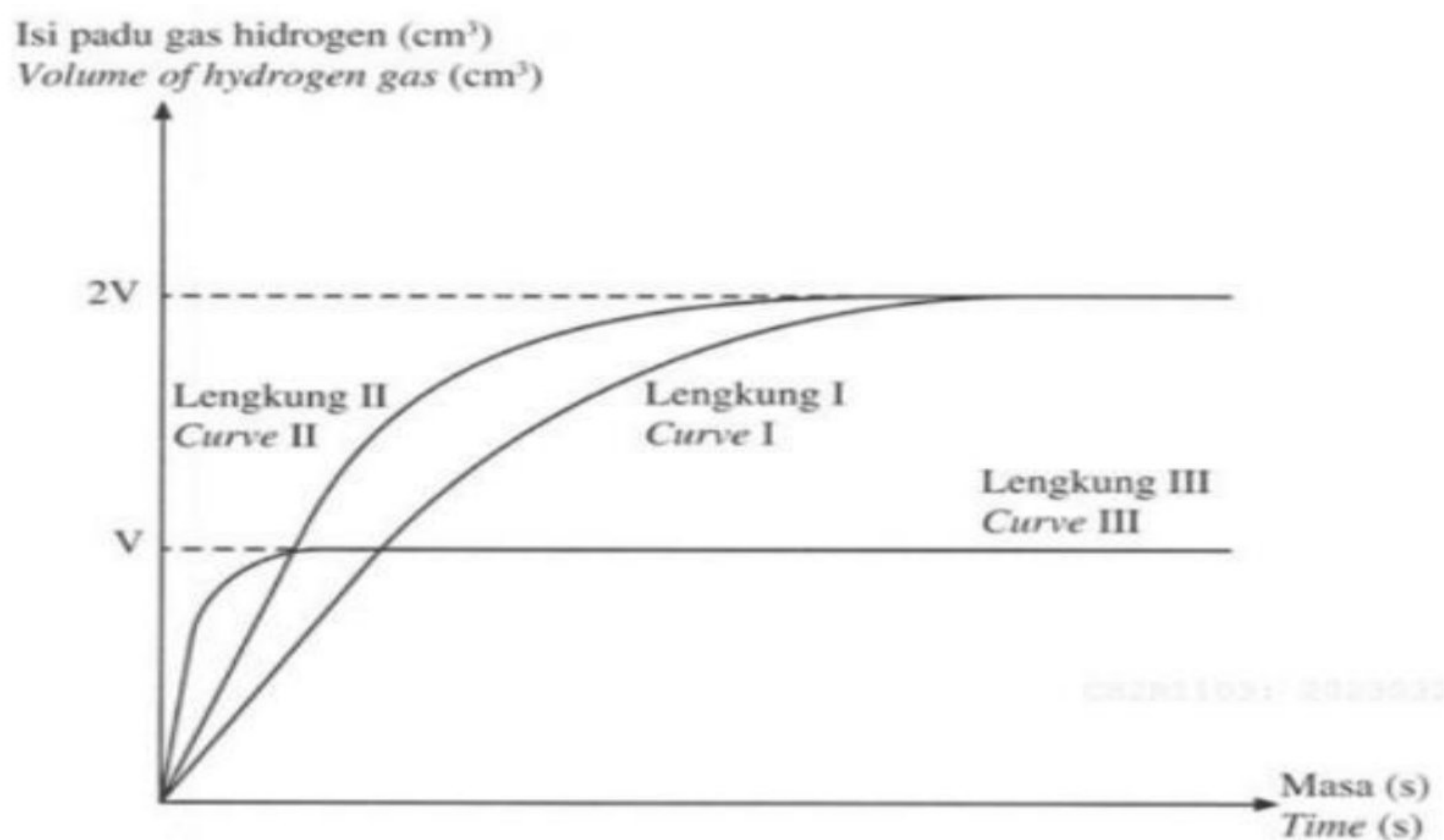

Rajah 12
Diagram 12

Ekhwan menjalankan satu eksperimen kadar tindak balas dengan menggunakan ketulan zink berlebihan dan 50 cm^3 asid hidroklorik 1.0 mol dm^{-3} . Isipadu gas hidrogen yang terkumpul di plot seperti lengkung I di dalam Rajah 12.

Ekhwan carried out an experiment of rate of reaction using granules of zinc and 50 cm^3 hydrochloric acid 1.0 mol dm^{-3} . Volume of hydrogen gas plots as shown as curve I in Diagram 12.

Cadangkan bahan yang boleh mendapatkan lengkung II dan III.

Suggest substances can be replaced to obtain curve II and III.

	Lengkung II <i>Curve II</i>	Lengkung III <i>Curve III</i>
A	Serbuk zink berlebihan dan 50 cm ³ asid hidroklorik 1.0 mol dm ⁻³ <i>Excess zinc powder and 50 cm³ hydrochloric acid 1.0 mol dm⁻³</i>	Serbuk zink berlebihan dan 25 cm ³ asid hidroklorik 1.0 mol dm ⁻³ <i>Excess zinc powder and 25 cm³ hydrochloric acid 1.0 mol dm⁻³</i>
B	Serbuk zink berlebihan dan 50 cm ³ asid sulfurik 1.0 mol dm ⁻³ <i>Excess zinc powder and 50 cm³ sulphuric acid 1.0 mol dm⁻³</i>	Serbuk zink berlebihan dan 25 cm ³ asid sulfurik 1.0 mol dm ⁻³ <i>Excess zinc powder and 25 cm³ sulphuric acid 1.0 mol dm⁻³</i>
C	Ketulan zink berlebihan dan 50 cm ³ asid sulfurik 1.0 mol dm ⁻³ <i>Excess zinc granule and 50 cm³ sulphuric acid 1.0 mol dm⁻³</i>	Ketulan zink berlebihan dan 25 cm ³ asid sulfurik 1.0 mol dm ⁻³ <i>Excess zinc granule and 25 cm³ sulphuric acid 1.0 mol dm⁻³</i>
D	Serbuk zink berlebihan dan 50 cm ³ asid hidroklorik 1.0 mol dm ⁻³ <i>Excess zinc powder and 50 cm³ hydrochloric acid 1.0 mol dm⁻³</i>	Serbuk zink berlebihan dan 25 cm ³ asid hidroklorik 1.0 mol dm ⁻³ beserta larutan kuprum (II) sulfat 1.0 mol dm ⁻³ <i>Excess zinc powder and 25 cm³ hydrochloric acid with copper(II) sulphate solution 1.0 mol dm⁻³</i>

- 40 Rajah 13 menunjukkan elektrolisis bagi asid hidroklorik yang berbeza kepekatan.
 Diagram 13 shows the electrolysis of hydrochloric acid with different concentrations.

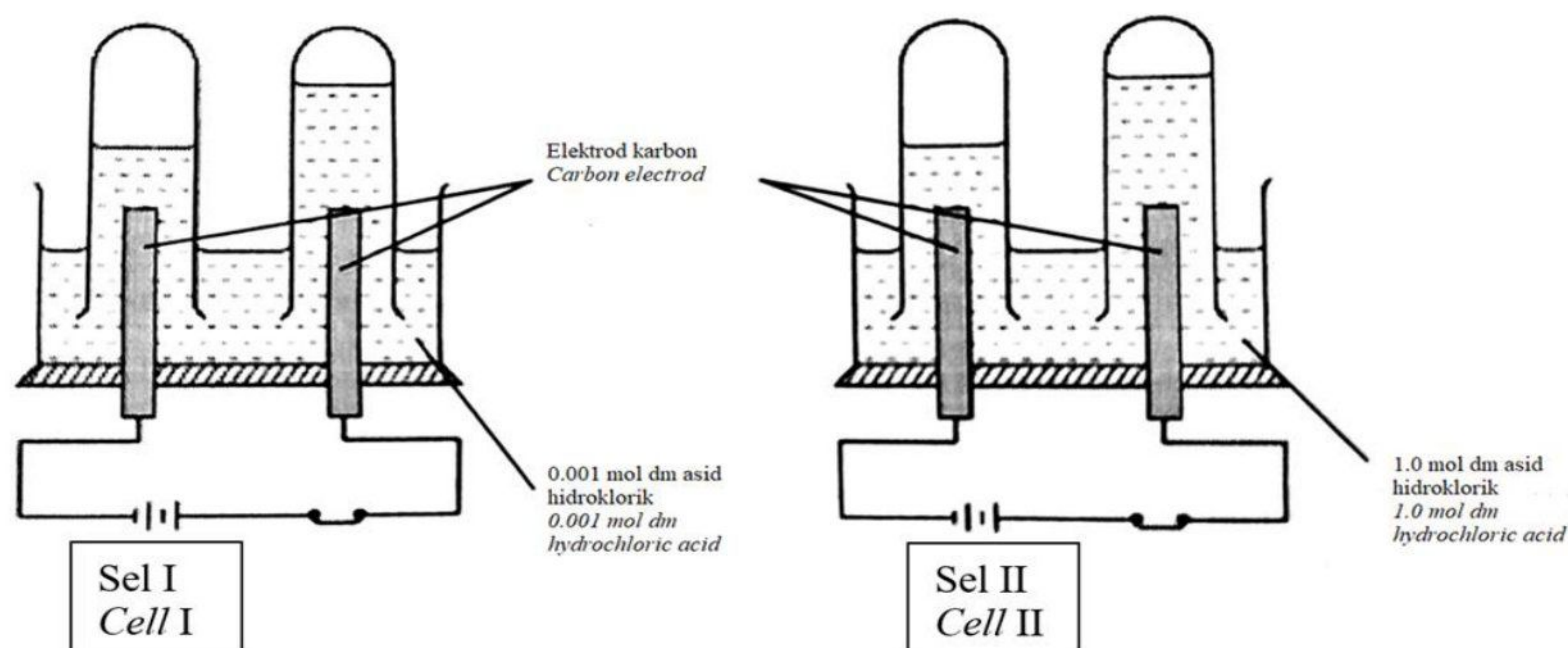

Rajah 13
 Diagram 13

Antara yang berikut, pernyataan manakah benar tentang Sel I dan Sel II?
 Which of the following statements is true about Cell I and Cell II?

	Sel I Cell I	Sel II Cell II
A	Kayu uji berbara menyala semula apabila dimasukkan ke dalam tabung uji di katod. <i>A glowing wooden splinter relights when it is put in the test tube at cathode</i>	Bunyi 'pop' terhasil apabila kayu uji menyala didekatkan ke mulut tabung uji di katod. <i>A 'pop' sound is produced when a lighted wooden splinter is put near the mouth of the test tube at cathode.</i>
B	Ion-ion Cl ⁻ dan OH ⁻ bergerak ke katod. <i>Cl⁻ and OH⁻ ions move to the cathode.</i>	Ion-ion Cl ⁻ dan OH ⁻ bergerak ke anod. <i>Cl⁻ and OH⁻ ions move to anode.</i>
C	Gas yang tak berwarna dihasilkan di anod dan di katod. <i>Colourless gas bubbles release at the anode and cathode.</i>	Gas tak berwarna dihasilkan di katod. Gas berwarna kuning kehijauan dihasilkan di anod. <i>Colourless gas bubbles release at the cathode Greenish yellow gas released at anode.</i>
D	Setengah persamaan di katod : <i>Half equation at cathode :</i> $2\text{H}^+ + 2\text{e} \rightarrow \text{H}_2$	Setengah persamaan di anod : <i>Half equation at anode :</i> $4\text{OH}^+ \rightarrow 2\text{H}_2\text{O} + \text{O}_2 + 4\text{e}$

KERTAS SOALAN TAMAT
END OF QUESTION PAPER

[Lihat halaman sebelah
 SULIT

**MAKLUMAT UNTUK CALON
INFORMATION FOR CANDIDATES**

1. Kertas soalan ini mengandungi **40** soalan.
*This question paper consists of **40** questions.*
2. Jawab **semua** soalan.
*Answer **all** questions.*
3. Tiap-tiap soalan diikuti oleh empat pilihan jawapan, iaitu **A, B, C** dan **D**. Bagi setiap soalan, pilih **satu** jawapan sahaja. Hitamkan jawapan anda pada kertas jawapan objektif yang disediakan.
*Each question is followed by four alternative answers, **A, B, C** and **D**. For each questions, choose **one** answer only. Blacken your answer on the objectives answer sheet provided.*
4. Jika anda hendak menukar jawapan, padamkan tanda yang telah dibuat. Kemudian hitamkan jawapan yang baharu.
If you wish to change your answer, erase the blackened mark that you have done. Then blacken the new answer.
5. Rajah yang mengiringi soalan tidak dilukis mengikut skala kecuali dinyatakan.
The diagrams in the questions provided are not drawn to scale unless stated.
6. Anda dibenarkan menggunakan kalkulator saintifik.
You may use a scientific calculator.